

Dec. 17, 1963

K. W. BACON ETAL
BOBSLED AMUSEMENT RIDE

3,114,332

Filed May 16, 1960

7 Sheets-Sheet 1

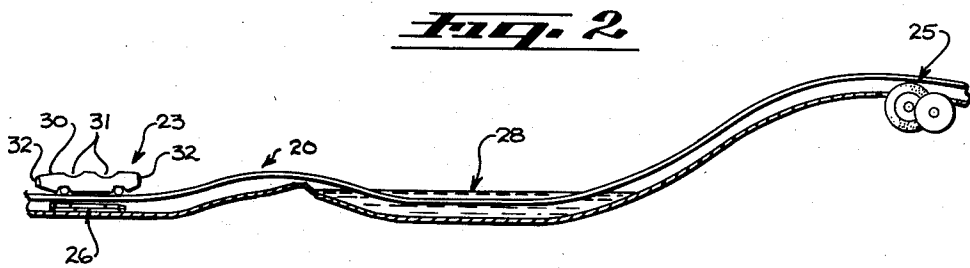
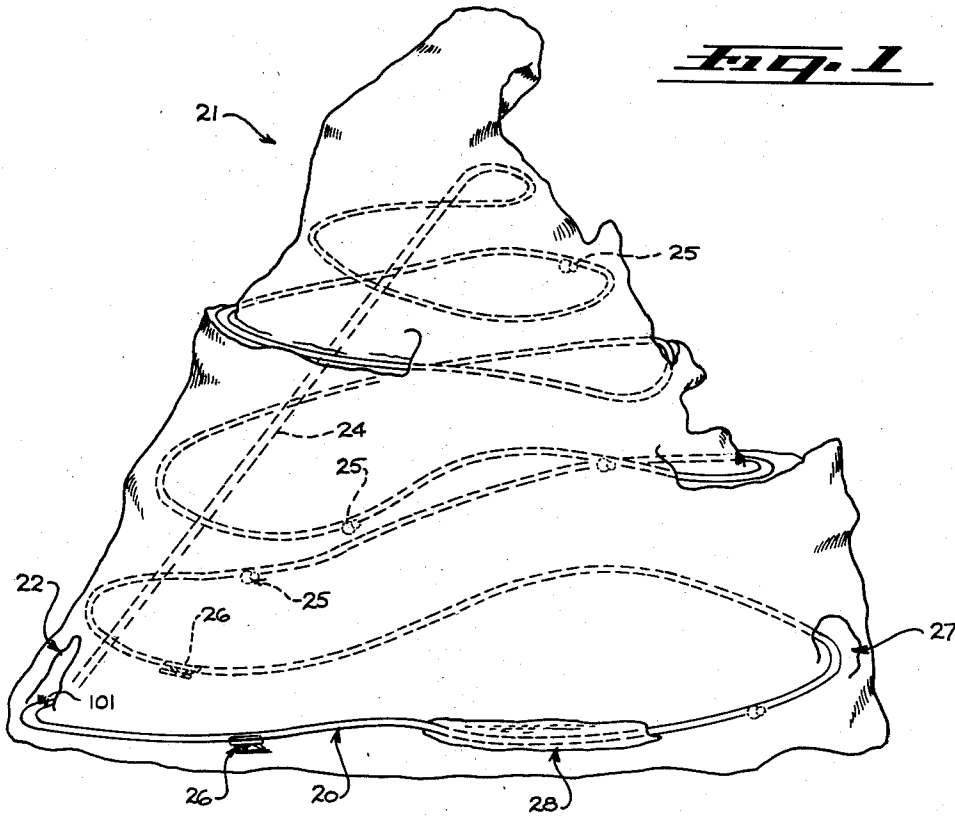

KARL W. BACON
EDGAR O. MORGAN
INVENTORS

BY **FULWIDER, MATTINGLY**
& HUNTLEY

ATTORNEYS

Dec. 17, 1963

K. W. BACON ETAL

3,114,332

BOBSLED AMUSEMENT RIDE

Filed May 16, 1960

7 Sheets-Sheet 2

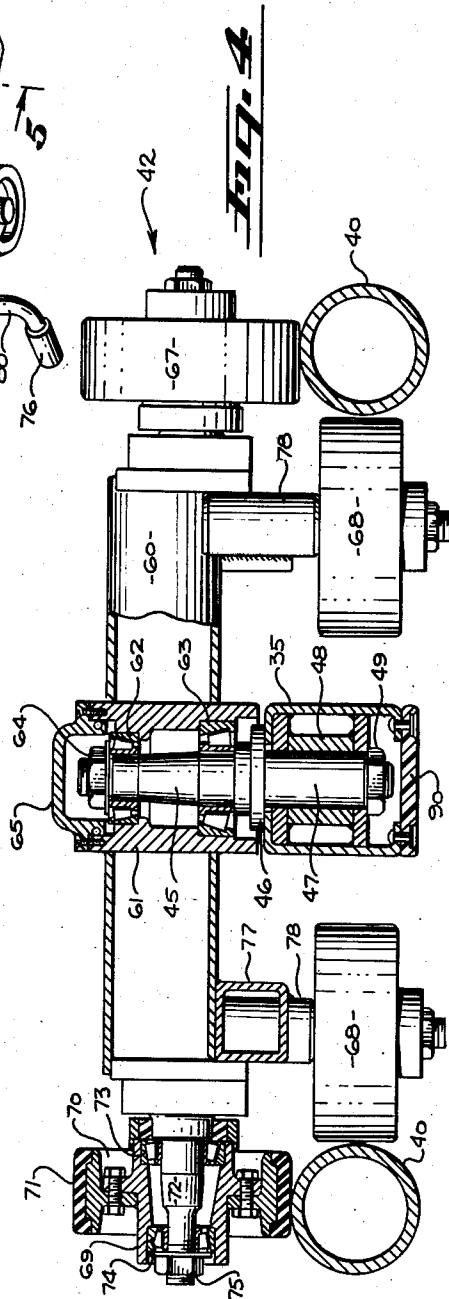
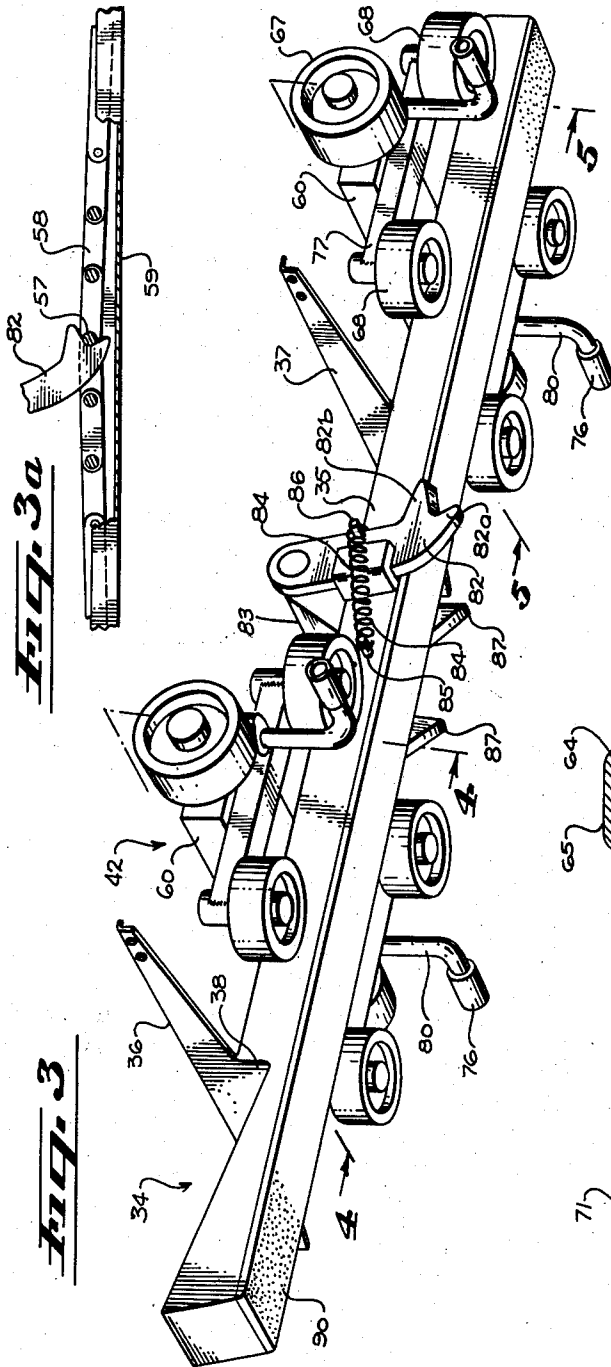

INVENTORS
KARL W. BACON
EDGAR O. MORGAN
BY
FULWIDER, MATTINGLY
& HUNTLEY

ATTORNEYS

Dec. 17, 1963

K. W. BACON ETAL
BOBSLED AMUSEMENT RIDE

3,114,332

Filed May 16, 1960

7 Sheets-Sheet 3

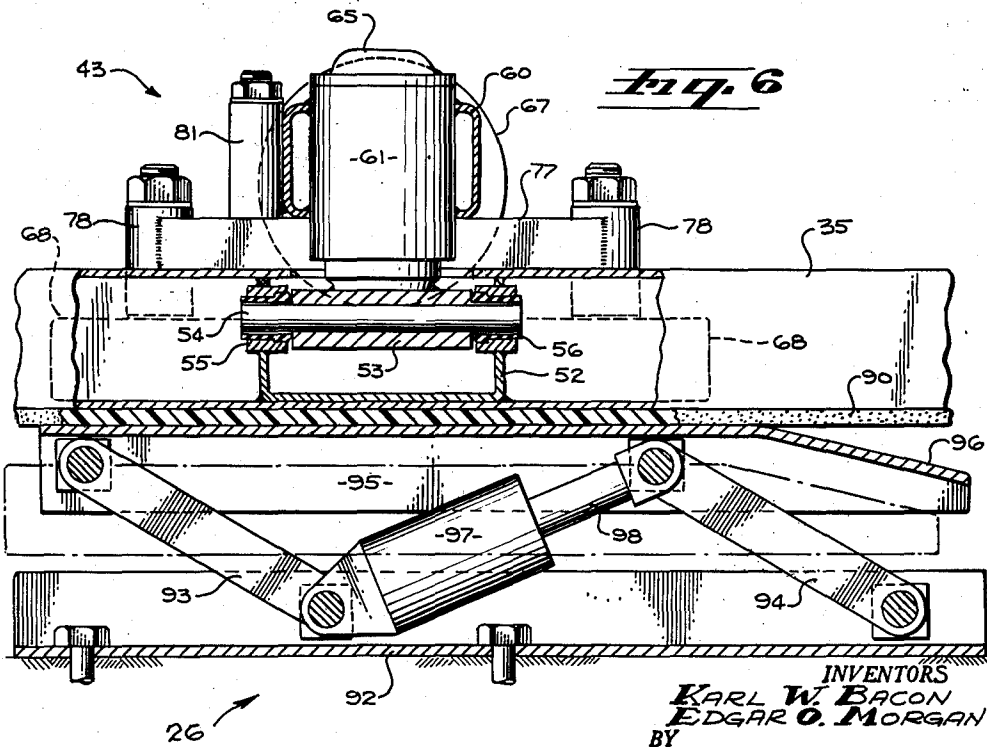
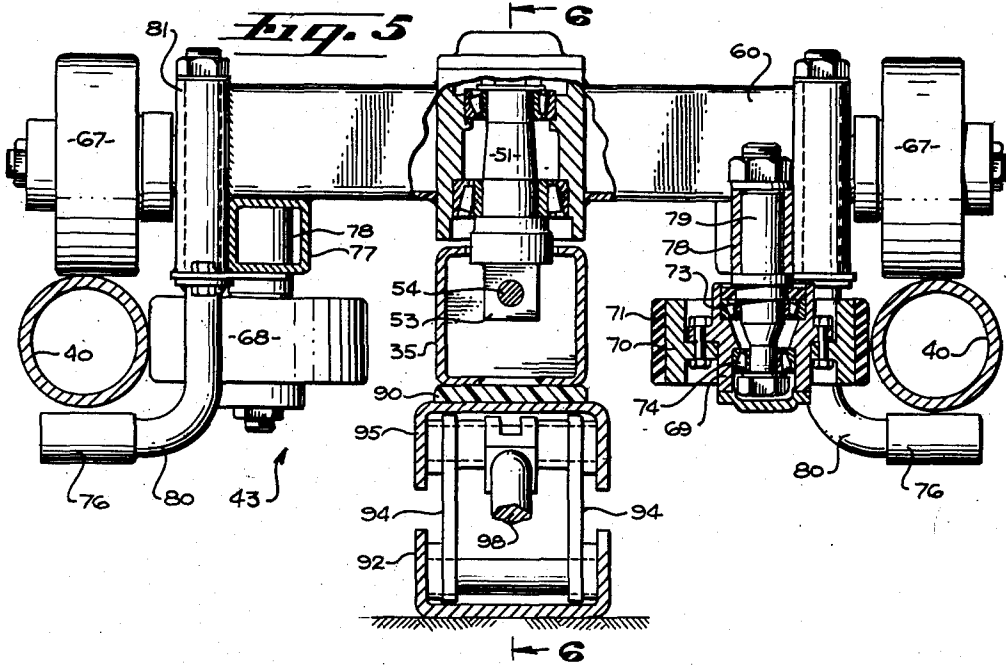

INVENTORS
KARL W. BACON
EDGAR O. MORGAN
BY
FULWIDER, MATTINGLY
& HUNTLEY

ATTORNEYS

Dec. 17, 1963

K. W. BACON ETAL

3,114,332

BOBSLED AMUSEMENT RIDE

Filed May 16, 1960

7 Sheets-Sheet 4

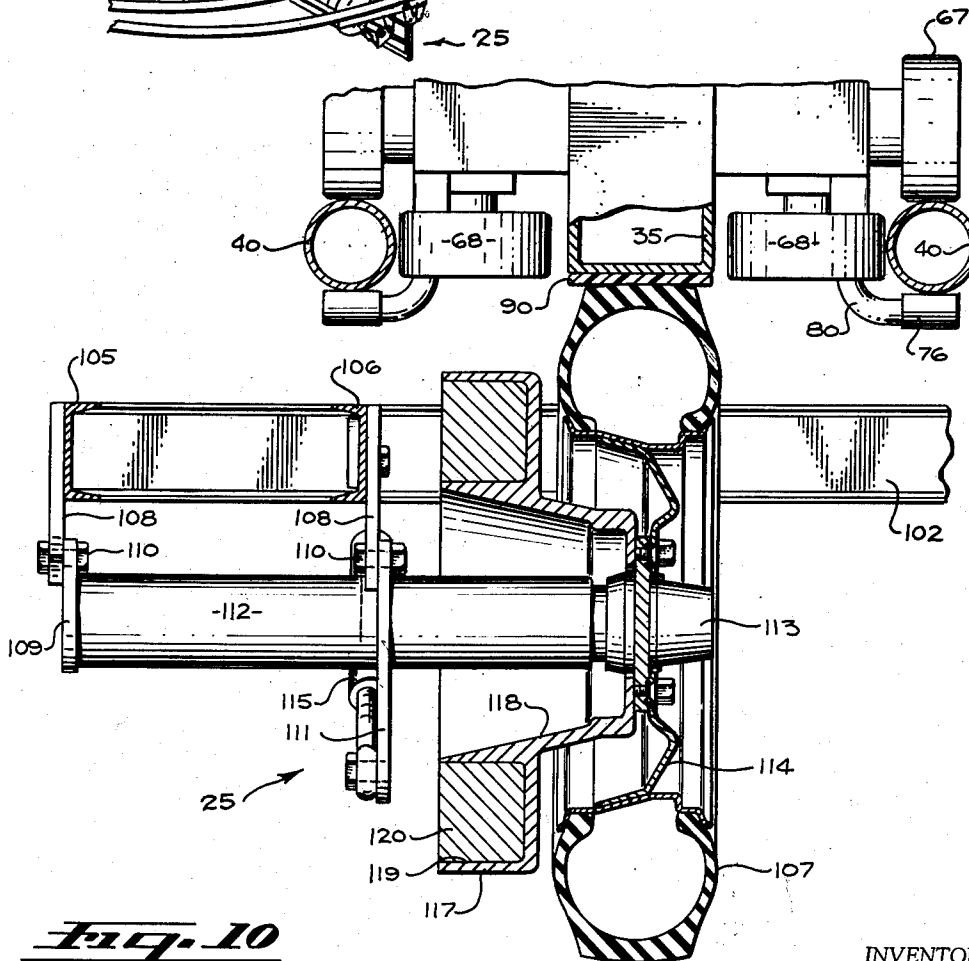
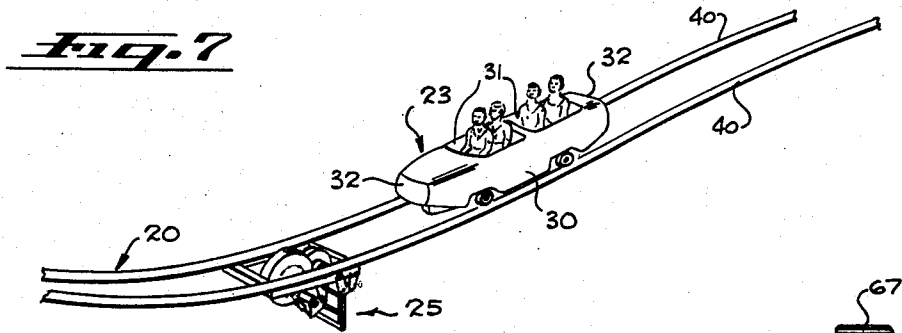

Fig. 10

INVENTORS
KARL W. BACON
EDGAR O. MORGAN

BY **FULWIDER, MATTINGLY**
& HUNTLEY

ATTORNEYS

Dec. 17, 1963

K. W. BACON ETAL
BOBSLED AMUSEMENT RIDE

3,114,332

Filed May 16, 1960

7 Sheets-Sheet 5

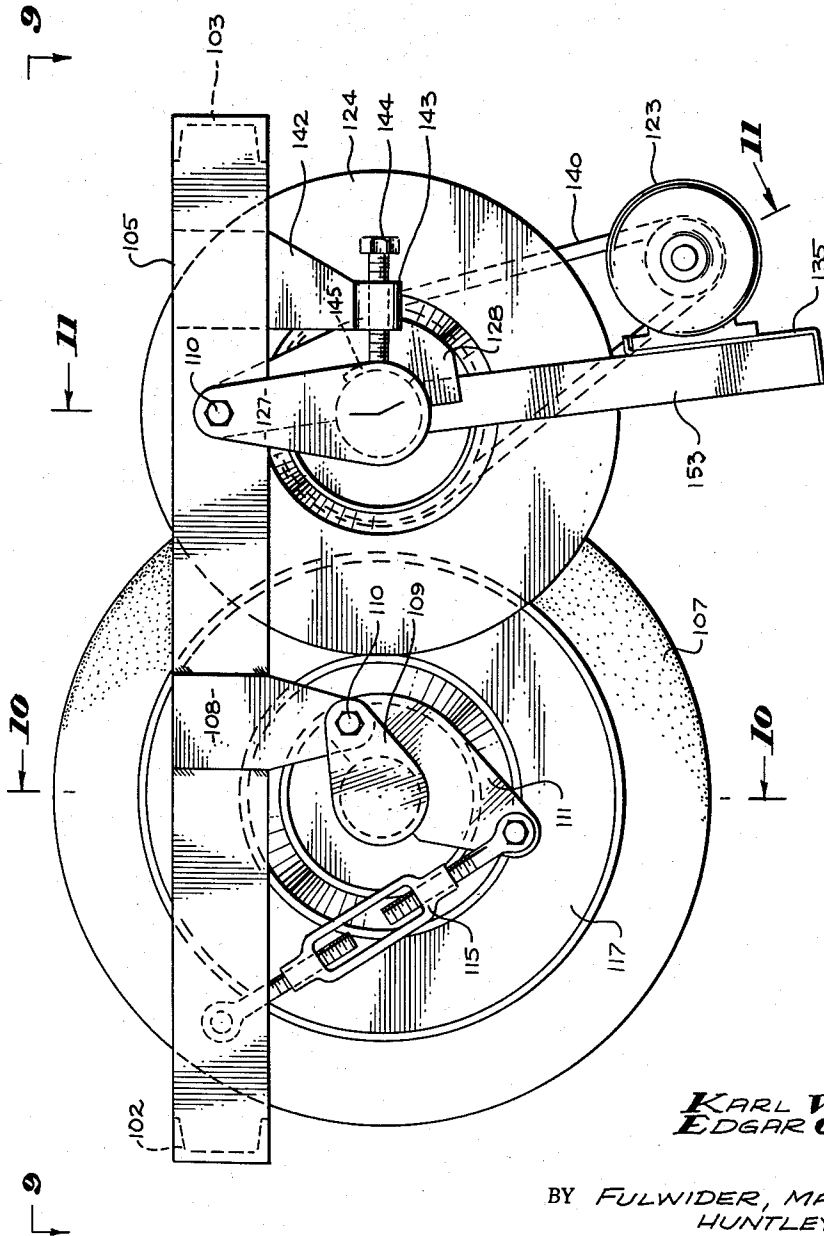

INVENTORS
KARL W. BACON
EDGAR O. MORGAN

BY **FULWIDER, MATTINGLY &**
HUNTLEY

ATTORNEYS

Dec. 17, 1963

K. W. BACON ET AL
BOBSLED AMUSEMENT RIDE

3,114,332

Filed May 16, 1960

7 Sheets-Sheet 6

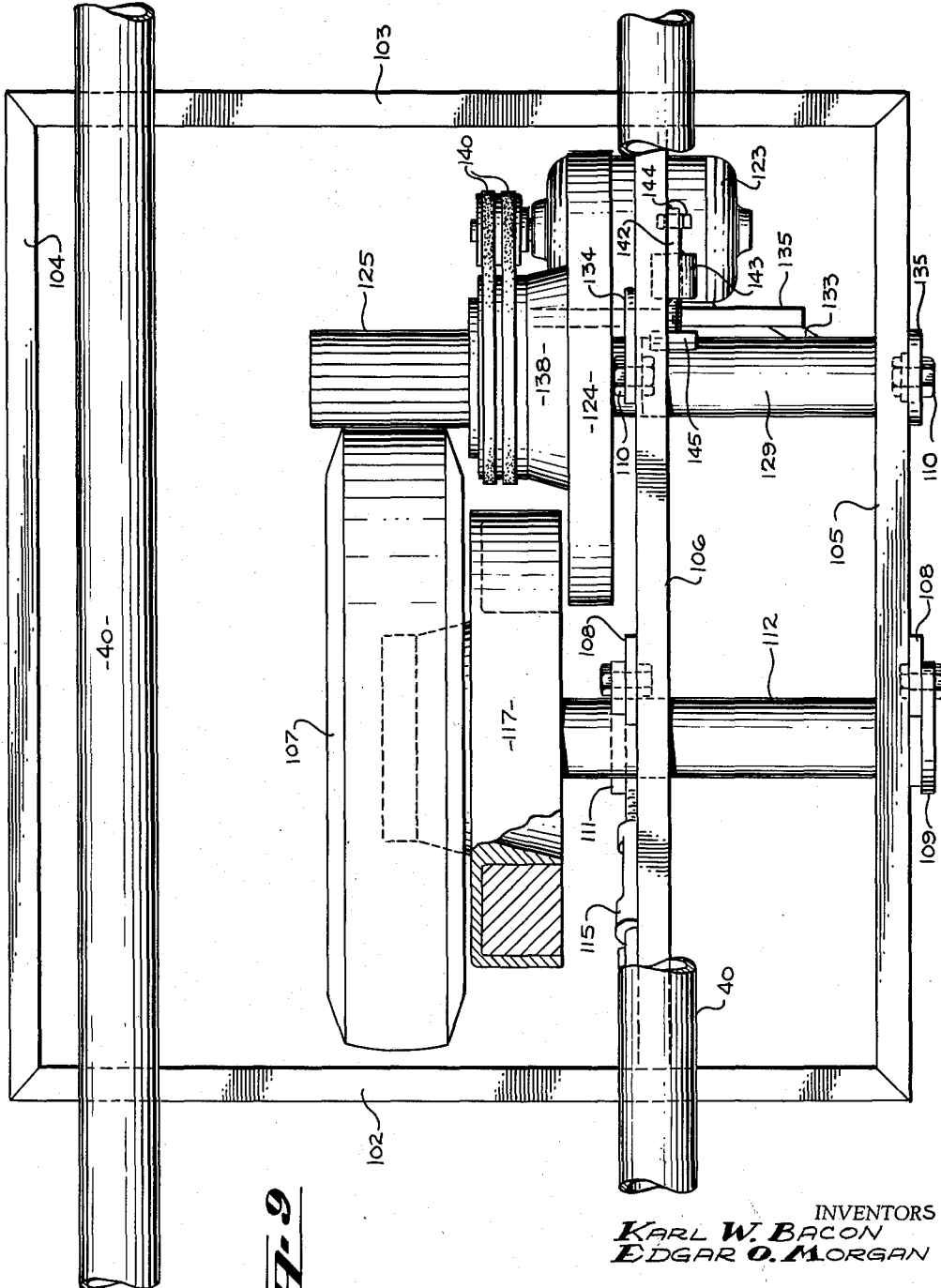

Fig. 9

INVENTORS
KARL W. BACON
EDGAR O. MORGAN

BY **FULWIDER, MATTINGLY & HUNTLEY**
ATTORNEYS

Dec. 17, 1963

K. W. BACON ET AL
BOBSLED AMUSEMENT RIDE

3,114,332

Filed May 16, 1960

7 Sheets-Sheet 7

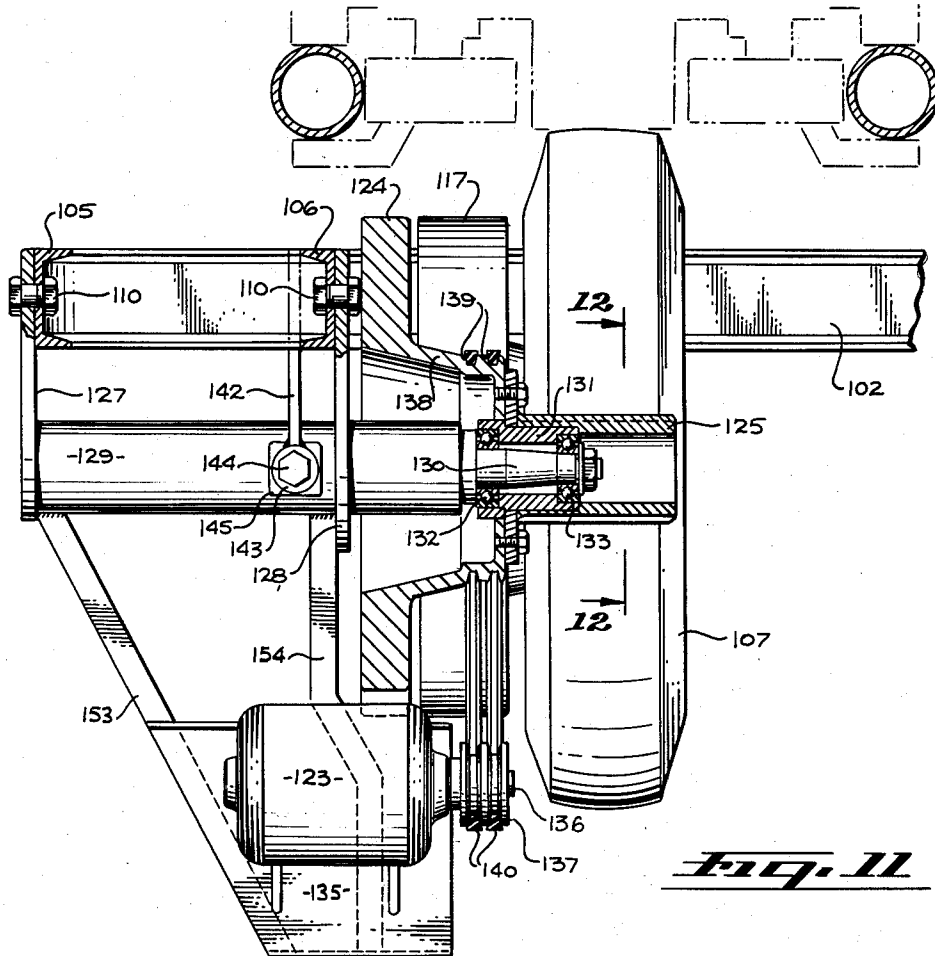

Fig. 11

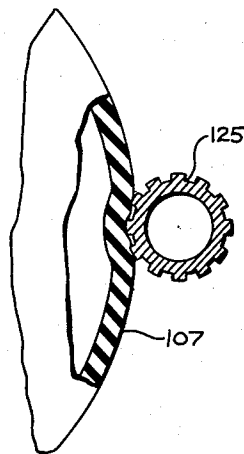

Fig. 12

INVENTORS
KARL W. BACON
EDGAR O. MORGAN

BY **FULWIDER, MATTINGLY &**
HUNTLEY

ATTORNEYS

1

3,114,332

BOBSLED AMUSEMENT RIDE

Karl W. Bacon, Mountain View, and Edgar O. Morgan, Palo Alto, Calif., assignors, by mesne assignments, to Walt Disney Productions, a corporation of California
Filed May 16, 1960, Ser. No. 29,366
14 Claims. (Cl. 104-63)

The present invention relates generally to amusement rides and more particularly to a ride of this type which simulates a bobsled descending an icy slope.

An object of our invention is to provide an amusement ride which realistically simulates a ride on a bobsled. For this purpose we have provided a ride in which individual cars coast down a sinuous track at a high rate of speed. The cars are adapted to seat the passengers in tandem, as on a bobsled, and the cars have wheels which simulate the sound of a bobsled sliding on ice or snow.

Another object of the invention is to provide a bobsled ride which will carry passengers at high speeds with absolute safety over a path that includes very sharp and highly banked curves, such as are found in a bobsled course.

It is also an object of the invention to provide a bobsled amusement ride which will carry a high volume of individual cars, without any danger that one car will overrun another.

Yet another important object of the invention is to provide a means for governing the speed of cars on a coaster ride; that is, a governor for reducing or increasing the speed of car passing over the governor to a prescribed rate.

Another object of the invention is to provide a ride of this type with cars that have wheel trucks adapted to pass over tightly curved and banked portions of the track without inducing extreme torsional stresses in the body of the passenger car, and for this purpose, we have provided an improved form of suspension system for the trucks.

A further object of the invention is to provide an improved brake mechanism for coaster ride cars which has a very high efficiency and reliability. Brakes of this improved type are positioned not only at the end of the ride to bring a car to a final stop, but are also utilized in blocks or sections of the track whereby, in emergency situations, any car may be halted to avoid overrunning a car in a subsequent section of the track. Furthermore, our brake is adapted to work with certainty even under adverse atmospheric conditions, such as during rainstorms. While adapted to operate with a high degree of reliability, the brake means will nevertheless bring a car to a stop at a comfortable rate of deceleration.

Yet another object of the invention is to provide an amusement coaster ride of this type with a water brake for decelerating a swiftly moving car to a greatly reduced rate of speed, for subsequently bringing the car to a comfortable, final stop.

These and other objects and advantages of our invention will be apparent from the following description when taken in conjunction with the annexed drawings in which:

FIGURE 1 is a perspective and somewhat schematic view of our bobsled amusement ride;

FIGURE 2 is an elevational view taken longitudinally of a section of the track, and partly in section, and particularly showing a water brake;

FIGURE 3 is a perspective view of a chassis for supporting one of the individual cars of the bobsled ride;

FIGURE 3a is a partial elevational view, partly in section of a chain drive means;

FIGURE 4 is a transverse sectional view taken on the line 4-4 of FIGURE 3 and showing details of construction of the front truck for the car;

2

FIGURE 5 is a sectional view taken on the line 5-5 of FIGURE 3 and showing details of construction of the rear truck of the chassis of the car, as well as a transverse sectional view of a portion of a brake;

FIGURE 6 is a longitudinal sectional view taken on the line 6-6 of FIGURE 5;

FIGURE 7 is a partial perspective view of a portion of the track and particularly showing one of the governors for a car descending the track;

FIGURE 8 is an elevational view of a governor;

FIGURE 9 is a top plan view of the governor shown in FIGURE 8;

FIGURE 10 is a sectional view on the line 10-10 of FIGURE 8;

FIGURE 11 is a sectional view on the line 11-11 of FIGURE 8; and

FIGURE 12 is a sectional view on the line 12-12 of FIGURE 11.

The general arrangement of the bobsled ride is best seen in FIGURE 1. It includes a continuous track, designated generally as 20, that is supported on the framework for a replica of a mountain or a hillside, such as Mount Matterhorn, and indicated generally by the numeral 21. The replica 21 has an opening 22, substantially at ground elevation, through which the track 20 initially enters into the hollow mountain. After this initial entrance one of a plurality of individual cars 23 is pulled up an ascending section 24 of the track 20 by an endless drive chain.

After a car 23 reaches the apex of the mountain 21 it is released to coast down the track 20. The descending section of the track is divided into blocks, which are not designated, and each block contains a governor means 25 and a brake means 26. The track 20 may pass in and out of the mountain 21 through several entrances and exits. As a car 23 descends the track 20, it passes over the several governor means 25 which regulate its speed to a predetermined rate for that particular section of track. It is to be appreciated that the speed of the car 23 will vary from time to time due to variations in the slope and curvature of various sections of the track 20, but the governor means 25 are preferably located with respect to a particular section of track so that all of the governor means 25 may be run at the same rate of speed. This arrangement is adapted to keep the speed of each car at a desired rate to avoid any possibility of one car overrunning another.

Each section of the track 20 is provided with a brake means 26 for halting a car in a section of the track preceding a subsequent section in which another car 23 may have become stalled. For clarity, the track 20 has not been represented as divided into specific sections and the number of brake means 26 shown does not correspond to the number of governor means 25 illustrated. It will be appreciated that the number and relation of governor means 25 and brake means 26 will be dependent upon the particular configuration of track 20 which is adopted.

A car 23 ultimately exists through another opening 27 in the mountain replica 21 and then passes through a body of water 28. The speed of the car is thereby greatly reduced upon leaving this body of water and the car is finally halted by a brake means 26 located in the passenger unloading area.

More specifically, each of the cars 23 has a body 30, which may be molded from Fiberglas or a plastic or otherwise constructed. One or more passenger compartments 31 are provided in the body 30. In practice, each of the compartments is adapted to seat a plurality of passengers in tandem, thus duplicating the seating arrangement of a bobsled. For safety, the car body 30 has side walls which hold the passengers within the compartment 31 but the body can be given a configuration otherwise suggestive

of a bobsled. To reduce the shock when a pair of the cars 23 collide, fore and end sections of the body 30 are provided with padded sections 32, of a resiliently deformable material. This padding inhibits damage to the framework of the car bodies when they collide, as they often do, during movements in the passenger unloading and loading areas. Obviously, the padded ends 32 also greatly reduce the danger of inquiry to the occupants of the cars in the event that one does overtake another.

Each car 23 is mounted on a chassis 34 such as is shown in FIGURE 3. This is a view of the chassis as it appears when viewed from beneath, with the forward end of the chassis being disposed towards the left in the figure. A longitudinally extending box beam 35 comprises the main support for the car body 30. A cross arm 36 is affixed in its central portion to the top of the beam 35 near the front end of the beam and another cross arm 37 is similarly affixed to the rear end portion of the beam. The underside of the body 30 is affixed to the cross arms 36 and 37 by a suitable fastening means. It will be noted that the upper face of the beam 35 slopes rearwardly and downwardly from the extreme front end of the beam until it reaches the front cross arm 36, whereby a forwardly facing shoulder 38 is defined on the beam. The underside of the car body 30 is formed with a complementary indexing configuration, or may have a complementary member attached thereto for seating against this shoulder 38.

The track 20 comprises a pair of tubular rails 40, preferably of circular cross-sectional configuration. These rails are anchored to the ground, or to the framework for the mountain replica 21 as aforesaid, by standards (not shown) which engage the horizontally outwardly facing sides of the rails 40. These rails are thus unobstructed on their horizontally inner faces and top faces to provide guiding surfaces for the wheel supports of the cars 23. The lower surfaces of the rails 40 are also unobstructed to provide surfaces against which safety devices secured to the cars 23 can abut to prevent the car from being thrown upwardly off the track 20.

In order to closely simulate a bobsled ride the track 20 has some tight, highly banked curves. Accordingly, in the curves the pair of rails 40 are not in a common horizontal plane. As a matter of fact, within the length of the wheel base of a car 23 the slope defined across the pair of rails 40 at a position corresponding to the location of the front wheel of a car 23 may be substantially different than the slope across the pair of rails at a position corresponding to the location of the rear wheel support for the car. Therefore, if the undersurface of the car body 30 were mounted in such a way that the front and rear portions assumed varying slopes in accordance with the different slopes across the track 20, severe torsional stresses would be imposed on the body 30. In order to avoid this we have devised a front truck assembly 42 and a rear truck assembly 43 which together enable a car 23 to negotiate these sharp, highly banked curves without torsionally stressing the body 30.

The front truck 42 is shown in FIGURE 4 and the rear truck 43 is shown in FIGURE 5. From a comparison of these two figures it will be observed that the two trucks are substantially similar but while the front truck 42 is mounted for pivoting only on a vertical axis, the rear truck 43 is mounted for movement on both vertical and horizontal axes, the horizontal axis extending longitudinally of the centerline of the beam 35. The rear truck 43 can thus assume a slope different from the slope of the front truck 42.

Referring to FIGURE 4, the front truck 42 is pivotally mounted on a vertical spindle 45. At about its midportion this spindle is integrally formed with a collar 46 which has a thrust seat on the upper face of the chassis beam 35. Beneath this collar the spindle 45 has a journal section 47 passing through an opening in the upper face of the chassis beam 35 and seated in a plain bearing

48 of a bearing box that is affixed within the chassis beam in the forward section thereof. A threaded lower end of the spindle 45 protrudes downwardly beneath the bearing 48 to receive a take-up nut 49 which bears against the lower end of the bearing box to keep the collar 46 in snug bearing engagement with the upper face of the chassis beam 35. The front truck 42 is thus secured to the chassis 35 for pivotal movement only about a vertical axis.

The rear truck 43 is supported for pivotal movement on a vertical axis by a vertical spindle 51. In order to support this spindle for pivotal movement on a horizontal axis disposed longitudinally of the chassis beam 35, the beam has a longitudinally extending bearing box 52 secured therewithin in the rear portion of the beam (see FIGURE 6). The lower end of the spindle 51 is integrally formed with an elongated plain bearing 53 to journal a shaft 54. The front and rear walls of the bearing box 52 have coaxially aligned sleeves 55 each of which is adapted to seat a bushing 56 and the opposite ends of the shaft 54 are mounted within these bushings. The rear truck 43 is thus mounted on the chassis 34 for pivotal movement about both vertical and horizontal axes, with the horizontal axis being disposed along the longitudinal centerline of the beam 35.

Apart from the differences in mounting just described, the front and rear trucks 42 and 43 are identical in construction. Thus both trucks include an axle member 60 comprising a substantially rectangular box beam having a central and vertically disposed housing 61 for receiving the upper end of the spindle 45 or 51, as the case may be. This housing seats a pair of axially spaced-apart tapered roller bearing supports 62 and 63 for the upper end of the spindle. Each of these spindles has a threaded upper end protruding upwardly beyond the upper tapered roller bearing 62, to receive a suitable fastening nut 64 and a washer thereunder. In order to protect the pivotal mounting, a suitable cap 65 is fastened on the upper end of the housing 61.

At each end the axle member 60 supports a vertically disposed wheel 67 and a tandem pair of guide wheels 68. The pair of wheels 67 have rolling contact with the upper faces of the pair of tracks 40 to support the car 23 and the tandem pairs of guide wheels 68 contact the inward faces of the tracks for steering the car by pivoting the truck around its vertical axis.

Each wheel 67 comprises a hub 69, a rim 70 and a tire 71. A pair of axle stubs 72 extends substantially coaxially from opposite ends of the axle member 60 and the stubs seat a pair of roller bearings 73, 74 for mounting the wheels 67, which are held in place by suitable fastening means 75. For mounting the guide wheels 68 in tandem, a member 77 is affixed to each end of the axle member 60, on the lower face of the axle member and extending longitudinally of the chassis 34. Equally spaced from the axle member 60 the member 77, on the opposite ends mounts a pair of vertically disposed sleeves 78 for the reception of stub axles 79. The lower ends of the pair of axles 79 support the guide wheels 68, which are of substantially the same internal construction as the wheels 67.

The tires 71 are preferably made of urethane rubber or other similar material combining high load capacity with resiliency. The peripheral surfaces of these tires are normally cylindrical but deform concavely to conform to the rails 40, the degree of deformation being proportional to the load. Thus, heavier passenger loads increase the tire deformation and "drag," tending to inhibit any tendency of heavily loaded cars to run faster than lightly loaded cars. In addition, the "drag" of the deformed tires produces a sliding sort of sound, like a bobsled.

As is customary in rides of this type, the ascending section 24 of the track 20 is provided with an endless chain and each car 23 is provided with a means engageable by the drive chain for lifting a car 23 up the slope of the peak of the mountain. Referring to FIGURE 3, the chassis beam 35 on one side has a dog 82 whose upper

end is pivotally supported from a bracket 83 affixed to the upper face of the beam. The near vertical side of the beam mounts a stop member 84 for limiting forward pivotal movement of the dog 82. A coil spring 84 extends between a pin 85 fixed to the side of the beam 35 and a pin 86 affixed to the dog 82. A cam face 82a is formed at the lower end of the dog beneath a spur 82b to be engaged by a pin 57 of the drive chain 33. This pin is thus cammed up out of its supporting trough 59 to minimize wear on the chain and trough, which do not receive the weight of the car. The spur 82b prevents the chain pin 57 from overriding the dog so no binding can occur. The pivot axis of the dog 82 is positioned relative to the stop 84 and the spur 82b to prevent the chain lifting a car against the up-stops 80, this also avoiding wear on the up-stops.

The ascending section 24 of the track also has a fixed rack element (not shown) between the rails 40 for preventing a car 23 from sliding backwardly down the ascending section. As is shown in FIGURE 3, the chassis beam 35, on the opposite side from the dog 82 has a similarly mounted pair of dogs 87 for engagement with the fixed rack element whereby retrograde movement of a car 23 is prevented.

In some sections of the track 20 there are abrupt increases of downward slope, tending to throw a speeding car 23 upwardly away from the track. In order to prevent a car from leaving the track, each truck 42 and 43 has a pair of L-shaped upstops or restraining members 80 whose upper ends are secured within sleeves 81 fastened to opposite ends of the axle member 60. The lower ends of the restraining members 80 project horizontally outwardly beneath the rails 40 and have a cylindrical member 76 replaceably sleeved thereover for sliding contact with the underside of the rails. Of course, rollers or the like may be used in lieu of members 76.

A car 23 is adapted for coaction with both the governor means 25 and brake means 26 by means of a friction element 90 covering the entire bottom face of the chassis beam 35 (see FIGURE 3). This friction element may comprise a brake lining material, such as asbestos, and may be a molded material, but we prefer the use of the woven types, usually comprising asbestos fiber, cotton fiber and copper or bronze wire. The woven material is preferred because it will absorb water more readily and a lining material which will absorb and retain a coolant liquid provides some advantages with our invention. However, it is to be understood that other types of friction element may be employed.

It has been mentioned that the track 20 is divided into blocks or sections and each of these blocks is provided with one of the brake means 26. Although not illustrated, the presently employed embodiment of this invention utilizes an electro-mechanical brake block system for actuating any one of the brake means 26 to hold a car 23 when another car is in an immediately subsequent block of the track. The construction and operation of the brake means 26 is best shown in FIGURE 6.

The brake means includes a base member 92, which may comprise an upwardly opening elongated channel anchored to a supporting surface parallel to and midway between a pair of rails 40. The base member pivotally supports the lower ends of parallel pairs of links 93 and 94 whose upper ends are pivotally secured to an elongated brake member 95. This brake member may also comprise a channel, but having a downwardly sloping face 96 at its rear end, comprising a continuation of the web of the channel. It will be observed that the pairs of links 93 and 94 and the members 92 and 95 comprise a parallelogram linkage whereby the brake member 95 can be raised and lowered between the dotted line and solid line positions illustrated.

For raising and lowering the brake member 95, a double acting fluid motor 97 is pivotally connected between the lower ends of the links 93 and the upper ends of links 94, i.e. on the short diagonal of the parallelo-

gram linkage. The motor 97 may be hydraulically or pneumatically operated and is conventional, its housing having a piston for reciprocating a piston rod 98. As is apparent, extension of the piston rod 98 causes the brake member 95 to be lifted into the braking position shown in FIGURE 6, whereas retraction of the piston rod causes withdrawal of the brake member to the dotted line position indicated.

In FIGURE 1, a water spray 101 can be seen at the entering opening 22 into the mountain replica 21. This spray operates as long as the bobsled ride is in operation. Since this spray 101 is disposed midway between the rails 40, a car 23 passing over the spray has its friction element 90 thoroughly wetted. This is important on hot days, which tend to dry out the friction element 90 because if there is any emergency actuation of one of the brake means 26, the car 23, due to the moisture of the friction element 90, is brought to a comfortable stop rather than to a stop so abrupt as to throw the passengers forwardly from the car. On the other hand, due to the great length of the friction element 90, there can be no danger of overwetting to the extent that it will lose all of its braking efficiency. Therefore, this arrangement of wetting the friction element is also important on rainy days since the friction element 90 has a sufficient length to insure stopping of the car 23 even though the upper surface of the brake element is wet and the friction element is completely saturated.

It will also be observed from FIGURE 1, that after the car 23 leaves the exit opening 27, it passes through the body of water 28 which resists passage of the car, slowing it to a very low rate of speed before the car enters the passenger unloading section. However, the body of water 28 is also important in insuring that the friction element 90 remains wet, even though the car may have been subjected to one or more emergency stops on preceding sections of the track 20.

The governor means 25 is shown in detail in FIGURES 7 through 12. An anchoring framework is provided for mounting each governor in a position between the rails 40 and is so arranged as not to interfere with the passage of the restraining members 80, guide wheels 68 or support wheels 67 of a car 23. This framework is substantially rectangular, comprising opposite end members 102 and 103 and opposite side members 104 and 105. Another frame member 106 extends between the opposite end members 102 and 103, extending parallel to the side members 104 and 105 and spaced approximately beneath one of the rails 40. This entire framework is spaced well beneath the rails 40, as is clearly shown in FIGURE 10.

Briefly, the governor means 25 comprises an endless cushioned element such as a tire 107, which is preferably pneumatic but may also be cushioned in other ways, as by filling with urethane foam, and that is inertially governed by a flywheel system. This tire is arranged along the longitudinal center line of the track 20 to be run over by the friction element 90 of a car 23. The tire is rotated at a constant speed, corresponding to the desired linear velocity of a car 23 passing thereover. Due to the inertia of the flywheel system, a slow car will be accelerated to the desired rate of speed while a speeding car will be retarded to the desired speed.

The illustrated cars 23 may carry any number of passengers between one and four, and the weight of the passengers may vary between wide limits. Accordingly, the momentum of the cars 23 may vary widely but the governor means 25 must be capable of changing the velocity of any car to the prescribed speed and this must be done within the fraction of a second during which the friction element 90 of the car runs over the tire 107. While this could be accomplished by a single inertia shaft governor coaxially mounting the tire 107, such an arrangement would entail an extremely large and cumbersome flywheel and motor. Accordingly, we have devised a system of plural flywheels and an arrangement allow-

ing a small motor to recover and stabilize the flywheel speed in the interval between cars.

The tire 107 is adjustably mounted in the desired position by the arrangement shown in FIGURES 8 through 10. A pair of brackets 108 are affixed, oppositely to one another, on the side member 105 and the intermediate longitudinally extending member 106. Both of these brackets extend downwardly beneath the supporting framework. The bracket 108, on the member 105, at its lower end pivotally supports an arm 109 on suitable fastener means 110, comprising a bolt and a pair of lock nuts which can be snugged up to aid in maintaining a desired position. Similarly, the lower end of the other bracket 108 pivotally adjustably supports another arm 111.

An axle housing 112 is affixed at one end to the arm 109 and is also supported in an intermediate portion by an intermediate portion of the other arm 111. An axle 113 is journaled in this housing and extends inwardly beyond the inner end of the housing to coaxially support a wheel 114. The rim of this wheel supports the inflated tire 107 in the desired position within the path of the friction elements 90 of the cars 23.

Vertical adjustment of the tire 107 is accomplished by means of a turnbuckle 115, one end of which is pivotally secured to the lower end of the arm 111 and the other end of which is pivotally secured to the intermediate member 106. In adjusting the tire 107, the fastener means 110 are first loosened and the turnbuckle then adjusted to cause the tread of the tire 107 to intrude into the path through which the friction element 90 of a car 23 will pass. The fastener means 110 are then snugged up, and the tire 107 is securely held in place against impulsive contacts with the friction elements 90 of the several cars passing over the governor means 25. It should be noted that the use of a pneumatic tire 107 causes cushioning of the impact of a friction element 90, whereby this impact is scarcely discernible by the occupants of the car, and also insures adequate frictional contact.

The hub of the wheel 114 also has a governor wheel 117 secured thereto. Referring to FIGURE 10, it will be seen that the governor wheel 117 has a generally cup-shaped hub section 118 extending axially away from the wheel 114 and also flaring radially outwardly from the axle housing 112. An axially facing annular space 119 is formed in the rim section of the governor wheel and this space is entirely filled with a very heavy material 120, such as lead, whereby a very great proportion of the weight of the governor wheel is concentrated in the rim.

For driving and governing the tire 107 and its coaxial governor wheel 117, the framework also supports a motor 123 for turning a governor disk 124 and a drive member 125, mounted coaxially with the disk and in driving engagement with the tire 107. The motor 123, disk 124 and drive member 125 have a common support means which, in turn, is adjustably mounted on the governor framework for controlling the engagement between the drive member 125 and the tire 107.

This adjustable support means includes an arm 127 and another arm 128, both of these arms being pivotally adjustably suspended from the side member 105 and intermediate member 106, respectively, by other fastening means 110. The lower ends of the arms 127 and 128 have an axle housing 129 secured thereto and extending inwardly beyond the vertical plane of the member 106. An axle 130 is mounted in the housing 129 to protrude from the inner end of the housing and mounts a hub assembly 131 including axially spaced-apart ball bearings 132 and 133. The drive member 125 and governor disk 124 are in turn coaxially secured to the hub assembly 131.

A pair of hanger straps 153 and 154 have upper ends secured to the axle housing 129 and at their lower ends support a plate 135 on which the motor 123 is mounted. This motor has a horizontally disposed output shaft 136 onto which a multigrooved pulley 137 is keyed. A generally cup-shaped hub section 138 of the governor disk 124 is formed with a pair of pulley grooves 139 aligned

with the grooves of the pulley 137. A pair of endless drive belts 140 drivingly interconnect the pulley 137 and the grooves 139 of the governor disk.

When the fastener means 110 shown in FIGURE 11 are loosened, the entire assembly just described can be moved towards and away from the tire mounting assembly. The extent of engagement of the drive member 125 and tire 107 can thus be controlled. Since the drive member 125 will naturally tend to rebound away from the tire 107, a setscrew mechanism is provided for holding the drive member in an adjusted position. Thus, a bracket 142 is secured at its upper end to the frame member 106 and in its lower end mounts an internally tapped sleeve 143 for the reception of a setscrew 144. This setscrew can be turned inwardly and outwardly of the sleeve and its inner end engages a pad 145 secured to the confronting face of the axle housing 129. When the drive member 125 has been properly adjusted the fastener means 110 are once again snugged up.

In operation, the motor 123 constantly turns at a speed which will give the desired linear velocity of the tread of the tire 107, corresponding, of course, to the desired velocity of a car 23. Obviously, if a car 23 passes over a governor means 25 at the prescribed rate of speed the linear velocity of the car's friction element 90 and of the tread of the tire 107 will be equal so that no alteration in the speed of the car occurs.

If a car 23 runs over a governor means 25 at an excessive rate of speed, its friction element 90 will tend to accelerate the tire 107. Some of the excessive momentum of the car 23 will be spent in accelerating the tire 107, which acceleration is resisted by the inertia of the governor wheel 117. There will be a momentary tendency for the governor wheel 117 to accelerate in absorbing the excessive momentum of the car 23 but the speed of the governor wheel and tire 107 is in turn governed by the inertia of the governor disk 124. Thus, any tendency toward acceleration of the tire 107 causes a difference in linear velocity of the tire tread and the periphery of the drive member 125. The inertially governed drive member 125 exerts a braking effect, holding the speed of the tire 107 to the prescribed rate. By the time the friction element 90 of a speeding car 23 has left the tread of the tire 107, it will have been slowed to the prescribed velocity.

When a car 23 passes over a governor means 25 too slowly, its friction element 90 will tend to decelerate the tire 107 and governor wheel 117. This deceleration will be resisted by the governor wheel, to cause an accelerating force to be imparted to the car 23. Once again, the tendency towards a change in velocity of the governor wheel 117 and tire 107 is resisted by the drive member 125 and its governor disk 124. Thus, the decelerating trend of the tire will cause a differential in the linear velocity of the tire tread and the periphery of the drive member, the faster inertially loaded drive member tending to compensate for the decelerating trend of the tire. As a result, by the time the very long friction element 90 of a car 23 has departed from the tire 107, the car will have been accelerated to the prescribed speed.

It will be apparent to those skilled in the art that various changes may be made in the amusement ride apparatus hereinabove described by the substitution of suitable equivalents. However, it should be understood that we do not wish to be limited to the specific form of apparatus disclosed but only by the spirit and scope of the appended claims.

We claim:

1. In an amusement ride the combination comprising: a track including a descending portion down which a passenger vehicle can coast; a passenger vehicle adapted for coasting on said track; and means mounted adjacent a descending portion of said track for running contact with a vehicle coasting down said track to govern the speed of said vehicle by altering the speed of said vehicle

9

to a predetermined rate in the interval during which said means has running contact with said vehicle.

2. In an amusement ride the combination comprising: a track including a descending portion down which a passenger vehicle can coast; a passenger vehicle having wheel means to support said vehicle on said track and to guide said vehicle along said track; inertia means mounted adjacent a descending portion of said track to maintain a desired speed of a vehicle coasting down said track, said means including an endless member arranged for running contact with a portion of said vehicle to alter the speed of said vehicle in accordance with the inertia of said member; brake means mounted adjacent said track adapted to be moved into and out of braking engagement with said portion of said coasting vehicle to halt said vehicle; and means to actuate said brake means.

3. In an amusement ride the combination comprising: a track comprising a pair of rails and including a descending portion down which a passenger vehicle can coast; a passenger vehicle having wheel means to rollingly support said vehicle on said rails; a wheel mounted between said rails for substantially tangential running contact with a longitudinally extending bottom surface of a vehicle coasting down said descending portion of said track; and inertia means to rotate said wheel at a desired speed whereby the speed of a vehicle running over said wheel can be altered by the speed of said wheel.

4. In an amusement ride the combination comprising: a track including a descending portion down which a passenger vehicle can coast; a passenger vehicle having wheel means to rollingly support said vehicle on said track; a wheel mounted for substantially tangential running contact with a longitudinally extending surface of a vehicle coasting down said descending portion of said track; and means to rotate said wheel at a desired constant speed whereby the speed of a vehicle running over said wheel can be altered by the speed of said wheel whenever there is a difference between the speeds of said wheel and said vehicle.

5. In an amusement ride apparatus the combination comprising: a track comprising a pair of rails and including a descending portion down which a passenger vehicle can coast; a passenger vehicle having wheel means to rollingly support said vehicle on said rails for coasting down said track, said vehicle having a friction element secured to the bottom surface of said vehicle and extending longitudinally between front and rear ends of said vehicle; a wheel-supported resilient tire mounted between said rails for running contact with said friction element of a vehicle coasting down said descending portion of said track; flywheel means associated with said tire to inertially resist a change in speed of said tire when said friction element of a vehicle runs over said tire; an elongated brake member mounted between and extending longitudinally of said rails, downwardly of said track from said tire, for movement between raised and lowered positions, said brake member in raised position being positioned for braking engagement with said friction element of a vehicle passing over said member; and power means to move said brake member between raised and lowered positions.

6. In an amusement ride the combination comprising: a track defined by a pair of rails; a passenger car supported on said rails for coasting along said track by wheel means; a pneumatic tire mounted coaxially with a flywheel on an axle, said axle being journaled in an axle housing; means to support said housing, axle, flywheel and tire for frictional rolling contact of said tire with a longitudinally extending bottom portion of said car when said car coasts along said track, said means being adapted for adjustment of said tire towards and away from the path of said car; a cylindrical drive member mounted coaxially with a governor disk on an axle, said axle being journaled in a housing, said drive member, said disk, said axle and said housing having a supporting frame in com-

10

mon with a motor, said motor having driving engagement with a hub portion of said disk through an endless belt means; and a means supporting said frame for adjusting said drive member into and out of driving engagement with said tire.

7. In an amusement ride the combination comprising: a track having a generally descending portion; a passenger car supported on said track for coasting down said descending portion of said track; and a plurality of car speed control means positioned at spaced apart positions along said descending portion of said track for accelerating or decelerating a car descending on said track to a desired rate of speed for that portion of the track at which each of said speed controls is located, each of said speed controls comprising a first and second means, said first means moving longitudinally of said track in an endless path and adapted and arranged for frictional contact with said car when said car runs over said first means, said second means moving said first mentioned means at a substantially constant rate of speed whereby the frictional resistance of said contact of said car and of said first mentioned means causes a change in the speed of said car whenever there is a differential in the speed of said car and the speed of said first means.

8. In an amusement ride the combination comprising: a track having a generally descending portion; a passenger car supported on said track for coasting down said descending portion of said track; a plurality of wheels mounted at spaced positions along said descending portion of said track, each of said wheels being mounted for frictional rolling contact with a longitudinally extending surface of said car when said car coasts down said track; and flywheel means associated with each of said wheels to inertially resist a change in speed of said wheel when there is a difference in the linear speeds of contacting portions of said wheel and car whereby to accelerate or decelerate said car to a desired rate of speed.

9. An apparatus as set forth in claim 8 in which said wheel includes a pneumatic tire and said car has a tire contacting friction element secured to the bottom surface thereof.

10. In an amusement ride the combination comprising: a track defined by a plurality of rails and having a generally descending portion; a passenger car supported on said rails for gravitationally coasting down said descending portion of said track; a plurality of rotary elements mounted at spaced apart positions along said descending portion of said track, each of said rotary elements being mounted between rails of said track for frictional contact with a longitudinally extending surface of said car when said car coasts down said track and over said element; a flywheel for each of said rotary elements mounted coaxially with said element to inertially resist a change of speed of said element when there is a difference in the linear speeds of contacting portions of said element and car; and a means to rotate each of said elements and flywheels at a desired linear speed of the periphery of said element whereby to accelerate or decelerate said car to a desired speed.

11. In an amusement ride the combination comprising: a track defined by a pair of rails and having a generally descending portion; a passenger car supported by wheel means on said rails for gravitationally coasting down said descending portion of said track; a plurality of car speed control wheels mounted at spaced positions along said descending portion of said track for frictional rolling contact of a resiliently deformable periphery of said wheel with a longitudinally extending surface of said car; a means for each of said wheels having driving engagement with said wheel to spin said wheel at a desired linear speed of the wheel's periphery; and a flywheel means for each of said wheels to inertially resist a change in speed of said wheel when there is a difference in the linear speeds of contacting portions of said wheel and car.

12. In an amusement ride the combination comprising:

11

a track defined by a pair of rails and having a generally descending portion; a passenger car supported by wheel means on said rails for gravitationally coasting down said descending portion of said track; a plurality of car speed control wheels mounted at spaced positions along said descending portion of said track for frictional rolling contact with a longitudinally extending bottom surface of said car when said car coasts down said descending portion over said track and over said wheel; a flywheel for each of said speed control wheels mounted coaxially with said wheel to inertially resist a change in speed of said wheel when there is a difference in the linear speeds of contacting portions of said wheel and car; a plurality of drive means, one for each of said speed control wheels, each of said drive means having driving engagement with the periphery of said speed control wheel to spin said wheel at a desired linear speed of the wheel's periphery; and a flywheel means for each of said drive means and mounted coaxially therewith to inertially resist a change in speed of said drive means as a result of a difference of linear speeds of contacting portions of said wheel and car.

13. In an amusement ride the combination comprising:

- a track comprising a pair of rails and including a descending portion down which a passenger vehicle can coast;
- a passenger vehicle having wheel means to rollingly support said vehicle on said rails for coasting down said track, said vehicle having a friction element secured to the bottom surface of said vehicle;
- wetting means that include a body of water through which said track passes to subject the underside of said vehicle and said friction element to wetting, said body of water having a sufficient depth over said track to decelerate said vehicle during the passage of said vehicle through said body of water as said vehicle passes through said body of water;
- a brake member mounted between said rails for movement between raised and lowered positions, said brake member moving into said raised position after said vehicle has passed through said body of water for braking engagement with said friction element of said vehicle;
- and means to move said brake member between said raised and lowered positions.

12

14. Apparatus as set forth in claim 13 in which said brake member comprises one side of a parallelogram linkage, a side of said linkage opposite to said brake member being fixed in place whereby said brake member is movable into and out of position for frictional braking contact with said friction element of said vehicle, and in which a power means is provided for moving said brake member into and out of braking position, said power means including a double-acting fluid motor for extending and retracting therefrom a piston rod drivingly connected to said motor, said motor and piston rod being pivotally interconnected at opposite ends to opposite corners of said parallelogram linkage on the short diagonal of said linkage.

References Cited in the file of this patent

UNITED STATES PATENTS

325,386	Bliven -----	Sept. 1, 1885
401,352	Hosea -----	Apr. 16, 1889
467,293	Miller -----	Jan. 19, 1892
637,498	Burger -----	Nov. 21, 1899
690,814	Acklin -----	Jan. 7, 1902
737,409	Jackman -----	Aug. 25, 1903
754,698	Reed -----	Mar. 15, 1904
777,497	Cooper -----	Dec. 13, 1904
779,464	Bruce -----	Jan. 10, 1905
780,348	Jackman -----	Jan. 17, 1905
793,333	Weaver -----	June 27, 1905
1,074,185	Lockwood -----	Sept. 30, 1913
1,752,026	Phillips -----	Mar. 25, 1930
1,840,988	Traver -----	Jan. 12, 1932
1,847,733	Traver -----	Mar. 1, 1932
1,897,329	Ostrander -----	Feb. 14, 1933
2,027,684	Fageol -----	Jan. 14, 1936
2,034,816	Huguenin -----	Mar. 24, 1936
2,229,002	Cowey -----	Jan. 14, 1941
2,348,841	Oswald -----	May 16, 1944
2,575,914	Griffin et al. -----	Nov. 20, 1951
2,642,005	Cooper -----	June 16, 1953
2,660,128	Hayes -----	Nov. 24, 1953
2,891,486	Kolesa -----	June 23, 1959
2,951,455	Candlin -----	Sept. 6, 1960
2,954,744	Bonner -----	Oct. 4, 1960